



42371 Avenida Alvarado
Temecula, CA 92590
TOLL FREE (800) 454-2725
TEL (951) 296-3480
FAX (951) 296-3490
www.aquauv.com

Aqua Ultraviolet

Instructions for Installing 15/25/57 Watt UV In Skimmers

TABLE OF CONTENTS

Important Information.	1
Warranty.	2-3
Determine your Skimmer Style / Model 15 Watt	4
Determine your Skimmer Style / Model 25/57 Watt.	5
New Savio Skimmer Model Installation Instructions	6
Old Skimmer Model Installation Instructions.	7
Installing The Lamp.	8
Winterizing	9
Cleaning The Quartz Sleeve	9
Changing The Quartz Sleeve.	9
Incorrect Installation.	11
Replacement Parts.	12

THIS SECTION CAN BE USED FOR NOTES:

IMPORTANT INFORMATION



**THANK YOU FOR PURCHASING THE BEST
WE CAN HELP YOU**

Returning the product is expensive and time consuming for you, your retailer and for us, the manufacturer. Should you encounter any problems with your product, please call our toll free "HELP" line for assistance. **PLEASE DO NOT** return your product to the store! Your dealer or distributor cannot offer any warranty work or exchanges on your product.



**In the US please call
TOLL FREE 1 - 800 - 454 - 2725
(951) 296-3480 Outside the U.S.
THANK YOU!**

WARRANTY INFORMATION

Aqua Ultraviolet Systems are warranted against failure due to defects in materials and/or workmanship during the warranty period. This warranty covers defects occurring under normal use and applies to the original retail purchaser and may not be transferred. The warranty and remedies set forth herein are conditional upon proper storage, installation, use, maintenance and conformance with the applicable use. It will be based upon Aqua Ultraviolet's discretion as to whether the defects are of manufacturing origin. Any damages due to shipping and handling, packing, or installation are not covered by this warranty.

This warranty does not apply to appearance or accessory items. This warranty does not include damage due to handling, transportation, unpacking, set up, installation, repair or replacement of parts supplied by any other than Aqua Ultraviolet, improper maintenance, incorrect line voltage, modification, or repairs by the purchaser, abuse, misuse, neglect, accident, fire, flood, or other acts of God.

Any oral statements about product made by the seller, the manufacturer, their representatives or any other parties do not constitute warranties and shall not be relied upon by the user and are not part of this contract.

Neither the seller nor the manufacturer shall be liable for any injury, loss or damages, whether direct, incidental or consequential including but not limited to lost profits, lost sales, injury, inability to use the product and the user agrees that no other remedy is available.

Before installing, the user shall determine the suitability of the product for their intended use and the user shall assume all risk liability whatsoever in connection therewith.

To validate this warranty, mail the enclosed warranty card within 10 days of purchase along with proof of purchase (copy of sales receipt).

Warranty Period:

Complete Unit: One year from the date of purchase or 18 months from manufacturing date.

Limitations:

Warranty does not cover any malfunction from improper installation.

Warranty only applies to the original end user and is not transferable.

Warranty does not cover repairs done by anyone other than Aqua Ultraviolet.

Warranty is void if system is not plugged into a G.F.C.I. (Ground Fault Current Interrupter).

Warranty may not be modified by verbal statements by Aqua Ultraviolet, distributors, retailers, their agents or any other party.

Warranty covers the repair or prorated replacement of the Aqua Ultraviolet products. Aqua Ultraviolet denies all liability for any other loss including but not limited to loss of equipment, income, livestock or personal injury.

There is no warranty on the Quartz Sleeve.

There is no warranty on broken Lamps. Lamps are prorated by usage.

Warranty is voided by the following:

Product labels defaced or removed.

Product is improperly installed or maintained by user or agent.

Product is abused, misused or damaged by user or their agent.

Product damage is caused by electrical surges, electrical spikes, electrical brown outs or improper voltage.

Electrical cord has been cut.

Unit was run without water.

WARRANTY RETURN AND REPAIR

Any implied warranty granted under state law including warranties of merchantability or fitness for a particular purpose are limited to one year from the date of purchase or 18 months from the date of manufacture or as otherwise stated in the above warranty. Aqua Ultraviolet is not responsible for direct, indirect, incidental or consequential damages. Some states do not allow limitations on how long an implied warranty lasts and/or do not allow the exclusions or limitations of incidental damages so the above limitation and exclusion may not apply to you. This warranty gives you special legal rights and you may also have other rights that vary from state to state.

Warranty Returns or Repair Returns:

Please call Aqua Ultraviolet at (800) 454-2725 for a "Return Merchandise Authorization" (RMA) number. You must have a valid RMA from an Aqua Ultraviolet customer service representative before sending any product in for warranty or repair. Please have your serial number, date of purchase and product type available when calling for an RMA number.

All warranty returns or repair returns must come freight prepaid with an RMA number clearly marked on the outside of the box. All other returns will be refused. Aqua Ultraviolet will not be liable for any shipping cost to return warranty or repair items. Include a note in the box with your RMA number, name, address, daytime phone number and brief description of the reason for return or repair.

Be sure to return product in the same packing or similar packing and insure the package (we recommend sending it UPS). If you do not have or can't locate proper packaging, please call our customer service department and we will send you packaging for a minimal charge.

Aqua Ultraviolet shall not be responsible for damage or loss done by the shipper. Nor shall Aqua Ultraviolet be responsible for merchandise that arrives damaged due to improper packaging. All claims for loss and damage must be filed by the customer with the shipper.

If unit is found to be out of warranty we will contact you with the cost of repair. Your authorization is required prior to making any repairs.

DETERMINE YOUR SKIMMER, 15 WATT UV

A00357

15 Watt Clarifier Retrofit For Ponds up to 2000 gallons

Warning: Failure to follow these instructions correctly could result in voiding the warranty. Do not attempt repairs yourself, contact Aqua Ultraviolet. Always unplug the unit from its power source before opening the skimmer's lid. Care should be taken to avoid the possibility of electrical shock. If the unit falls into the water do not reach for it. First unplug the unit and then retrieve it. If any electrical component gets wet unplug the unit immediately. Do not operate this unit if it has a damaged cord or plug, or if the unit is malfunctioning or if it has been dropped or damaged in any way. Always unplug the unit when servicing the skimmer, cleaning, removing or replacing any parts of the unit or skimmer. Never yank the cord to pull the plug, grasp the plug to disconnect. Do not allow the unit to be entirely submerged. Do not allow the transformer to be submerged in water. Do not place transformer in the pond or in an area where water can pool. Do not operate the unit in a dry skimmer, damage may result. Damage caused by operating the unit dry is not covered under the warranty. Improper assembly may result in electrical component water damage, which is not covered under the warranty.

First determine if your Savio Skimmer is the New Style or Old Style by checking which baffle you have. See Diagram. If your baffle top has a large opening like the one on the right go to page 7. If your baffle looks like the one on the left go to page 6.

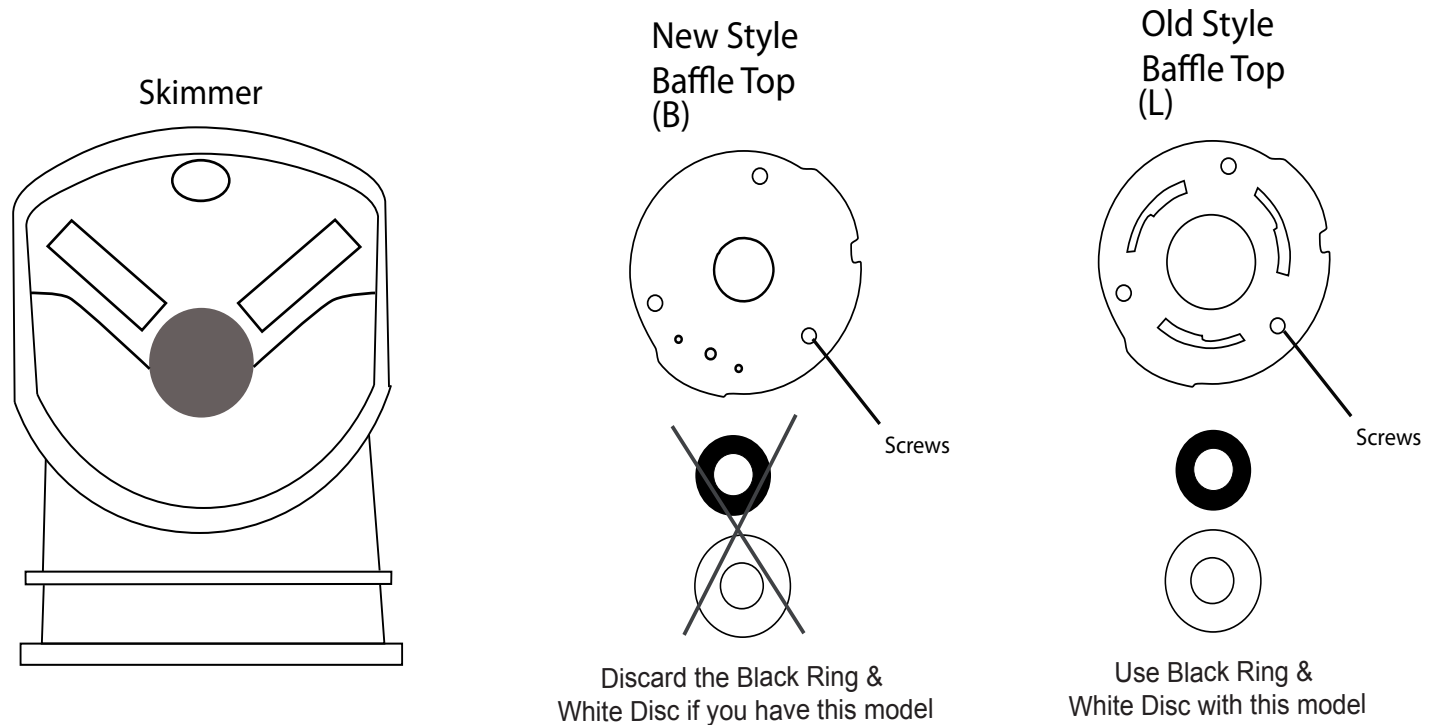

DETERMINE YOUR SKIMMER 25/57 WATT UV

A00333
A00332

25 Watt Clarifier Retrofit
57 Watt Clarifier Retrofit

For Ponds up to 4000 gallons
For Ponds up to 6500 gallons

Warning: Failure to follow these instructions correctly could result in voiding the warranty. Do not attempt repairs yourself, contact Aqua Ultraviolet. Always unplug the unit from its power source before opening the skimmer's lid. Care should be taken to avoid the possibility of electrical shock. If the unit falls into the water do not reach for it, first unplug the unit and then retrieve it. If any electrical component gets wet unplug the unit immediately. Do not operate this unit if it has a damaged cord or plug, if the unit is malfunctioning, or it has been dropped or damaged in any way. Always unplug the unit when servicing the skimmer, cleaning, removing or replacing any parts. Never yank the cord to pull the plug, grasp the plug to disconnect. Do not allow the unit to be entirely submerged. Do not allow the transformer to be submerged in water. Do not place transformer in the pond or in an area where water can pool. Do not operate the unit in a dry skimmer, damage may result. Damage caused by operating the unit dry is not covered under the warranty. Improper assembly may result in electrical component water damage, which is not covered under the warranty.

First determine if your Savio Skimmer is the New Style or Old Style by checking which baffle you have. See Diagram. If your baffle shield has a larger opening like the one on the left go to page 7. If your baffle shield looks like the one on the right go to page 6.

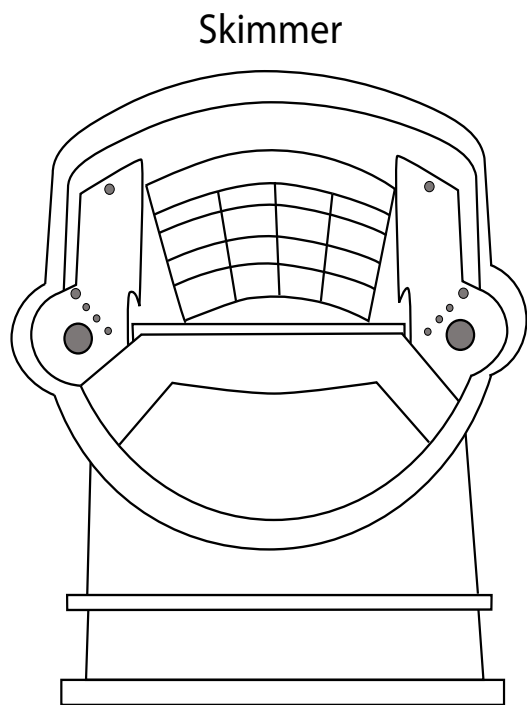

Old Style
Baffle Shield
(L)

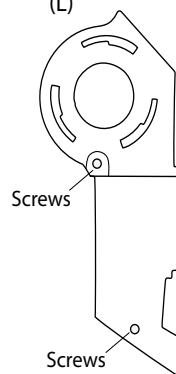

Use Black Ring & White
Disc with this model

New Style
Baffle Shield
(B)

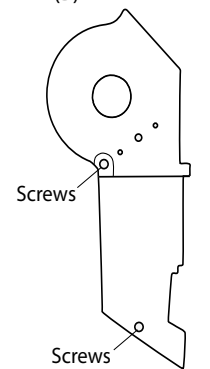

Discard the Black Ring & White
Disc if you have this model

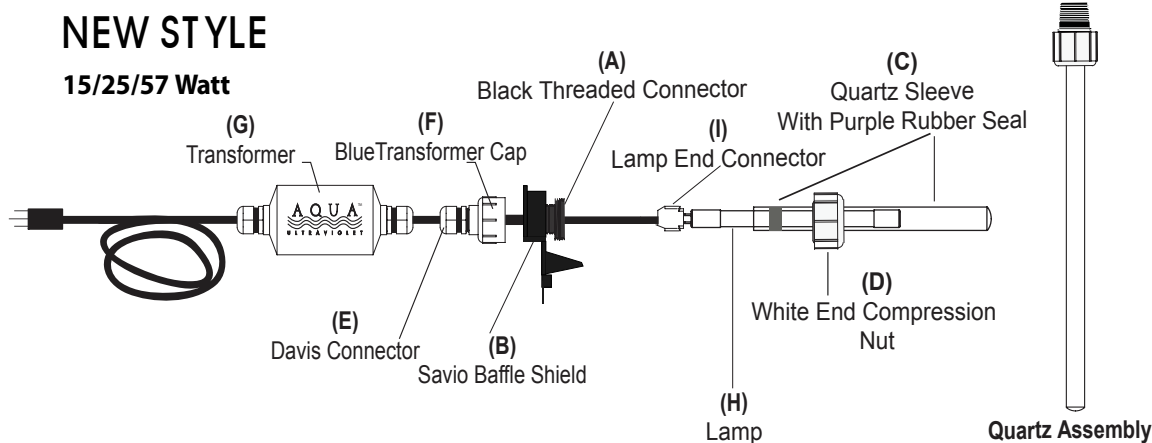

For The 15 Watt Installation:

1. Turn Pump off.
2. Remove the lid from your Savio Skimmer.
3. Remove the screws to take out the Baffle Shield (B).

For The 25/57 Watt Installation:

1. Turn Pump off.
2. Remove the 2 white vinyl screws to remove the lid from your Savio Skimmer.
3. If installing one UV you can use either the left or right Baffle Shield (UV mount) (B).
4. Remove the screws to take out the Baffle Shield (B).

Continue For 15/25/57

5. Test Fit the Quartz Assembly by placing the Black Threaded Connector (A) into the bottom of the Baffle Shield (B), placing the smaller side of the Black Threaded Connector (A) up through the Baffle Shield (B). If it is necessary use the Grinding Stone provided in the kit to file the opening of the Baffle Shield a little to allow the Black Threaded Connector to fit.
6. Hold Quartz Sleeve Assembly by the White Compression End Nut (D). Place the Baffle Shield over the Black Threaded Connector(A).
7. Do not install Lamp yet, follow the instructions below to check for leaks first.
8. Loosen the Davis Connector(E) behind the Blue Transformer Cap (F).
9. Be sure to support the Transformer (G) and cords while installing. Sitting down may be easier with putting the Transformer weight across your lap or on a table. Hand tighten the Blue Transformer Cap (F) on to the Black Threaded Connector (A). Then hand tighten the black Davis Connector Nut (E) behind the Blue Transformer Cap (F).
10. Install the retrofit Quartz Assembly into Baffle of the Skimmer. Insert the screws.
11. Do not plug in the Transformer at this time.
12. Run cord through slot on side of Skimmer. Do not allow electrical connection to get wet.
13. Place the top on the Skimmer.
14. Turn on pump and run for 10 minutes. Turn off pump. Remove the Skimmer Top. Unscrew the retrofit Baffle Top assembly and check the Clear Quartz tube for water.
15. If water is present, unscrew the White Compression End Nut. Check that the Purple Rubber Seal is in place. 1/4" should be showing below the Black Threaded Connector (A), retighten fittings.
16. Repeat test (step 14-15) until no leaks. If no leaks continue to step 17.
17. Loosen the Black Davis Connector (E) Nut behind the Blue Transformer Cap (F).
18. Unscrew Blue Transformer Cap (F).
19. Hold Baffle Assembly together by holding the White Compression Nut (D).
20. Continue on to installing the Lamp on page 8.

OLD STYLE INSTALLATION

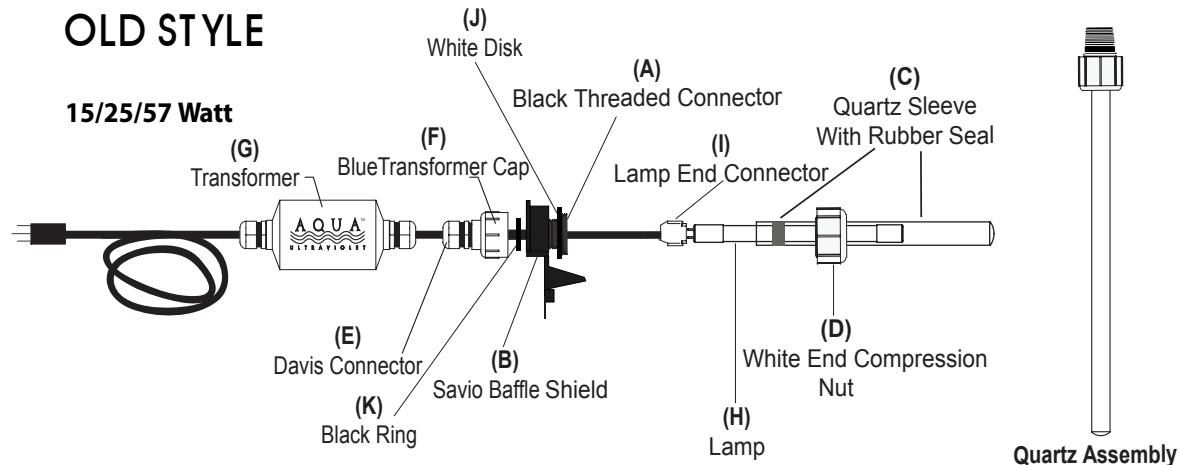

For The 15 Watt Installation:

1. Turn Pump off.
2. Remove the lid from your Savio Skimmer.
3. Remove the screws to take out the Baffle Shield (B).

For The 25/57 Watt Installation:

1. Turn Pump off.
2. Remove the 2 white vinyl screws to remove the lid from your Savio Skimmer.
3. If installing one UV you can use either the left or right Baffle Shield (UV mount) (B).
4. Remove the screws to take out the Baffle Shield (B).

Continue For 15/25/57:

5. Hold Clear Quartz tube assembly by the White Compression End Nut (D).
6. Take White Disk (J) place over the small end of the Black Threaded Connector (A).
7. Take the Baffle Shield (B) and place over the White Disk (J).
8. Take the Black Ring (K) and place over the top of the Baffle Shield (B).
9. Do not install Lamp (H) yet, follow the instructions below to check for leaks first.
10. Loosen the Davis Connector (E) behind the Blue Transformer Cap (F).
11. Be sure to support the Transformer (G) and cords while installing to test for leaks. Sitting down may be easier putting the Transformer weight across your lap or on a table. Hand tighten the Blue Transformer Cap (F) on to the Black Threaded Connector (A). Then hand tighten the small Davis Connector Nut (E) behind the Blue Transformer Cap (F).
12. Install the retrofit assembly into Baffle of the Skimmer. Insert the screws.
13. Do not plug in the Transformer at this time.
14. Run cord through slot on side of Skimmer. Do not allow electrical connection to get wet.
15. Place the top on the Skimmer.
16. Turn on pump and run for 10 minutes. Turn off pump. Remove the Skimmer Top. Unscrew the retrofit Baffle Top Assembly and check the Clear Quartz tube for water
17. If water is present, unscrew the White Compression End Nut. Check that the Purple Rubber Seal is in place. ¼" should be showing below the Black Threaded Connector (A), retighten fittings.
18. Repeat test (steps 16-17) until no leaks. If no leaks continue to step 19.
19. Loosen the Black Davis Connector Nut (E) behind the Blue Transformer Cap (F).
20. Unscrew Blue Transformer Cap (F).
21. Hold baffle assembly together by holding the White Compression Nut (D).
22. Continue on to installing the Lamp on page 8.

INSTALLING THE LAMP

1. Prevent finger marks on the Lamp. If you touch the Lamp use denatured alcohol and a soft cloth to clean the Lamp.
2. Note: Lamps and Quartz Sleeves should be handled with care. Lamps and Quartz Sleeves are not warranted against breakage.
3. Lamps need to be changed every 14 months.
4. Remove Lamp (H) from shipping tube and plug into the White Lamp End Connector (I). Be sure the Lamp and the Lamp End connector are flush.
5. Be very careful when installing the Lamp. If the Lamp is not plugged in all the way this may cause damage to the Retrofit Unit and is not covered under warranty nor is any damage caused by improper installation.
6. Do not drop the Lamp into the Quartz Sleeve, it will break the Quartz Sleeve.
7. Do not install the Lamp at an angle, even a slight angle; this may cause a “U” shaped crack at the end of the Quartz Sleeve or break the Lamp. If this should happen, do not proceed with the installation. Purchase a new Lamp or Quartz Sleeve from your dealer.
8. Do not force the Lamp into the Quartz Sleeve, any force would be an indication of improper installation.
9. Do not look at or handle UV Lamps when lit outside of the Skimmer Housing. Considerable Ultraviolet Energy is emitted which may produce severe sunburn and/or conjunctivitis.
10. Be sure to support the Transformer and cords while installing the Lamp. Sitting down may be easier with putting the Transformer weight across your lap or on a table. Take Lamp Assembly and install down into the Quartz Sleeve and hand tighten the Blue Transformer Cap (F). Then hand tighten the black Davis Connector Nut (E) behind the Blue Transformer Cap (F).
11. Take a damp towel and wipe finger prints from the Quartz Sleeve.

Install UV into Savio Skimmer

1. Install the newly assembled UV into the Skimmer. Insert the screws.
2. Place the power cord in the slot on the side of Skimmer.
3. Plug the UV into a GFCI receptacle, the Blue Transformer Cap (F) will glow.
4. If this unit is not plugged into a GFCI (Ground Fault Circuit Interrupter) the warranty is void. A surge suppressor should be added for extra protection, it is not needed, but recommended.
5. For 25/57 Watt: If you are only using one UV use a baffle block (See your Savio Instruction manual, this part is included with the skimmer) to close off water flow to the unused UV compartment, for ponds less than 3000 gallons. For ponds over 3000 gallons do not use baffle block.
6. For 25/57: Repeat the above steps if a second UV is to be installed.
7. Place top on Skimmer. Replace screws
8. Turn on pump.

Suggestion: If you are medicating, we recommend unplugging the UV as it may effect the treatment.

MAINTENANCE

Winterizing

1. Remove the Baffle Shield complete with the UV Assembly and store in a safe place.
2. Do not allow unit to be exposed to freezing temperatures, damage may result which is not covered under warranty.

Cleaning the Quartz Sleeve

1. Turn Pump off.
2. Remove the 2 white vinyl screws to remove the lid from your Savio Skimmer.
3. Remove the screws to take out the Baffle Shield complete with the UV Assembly.
4. Lime Away or similar products may be used. The Quartz Sleeve may need to be soaked over night or until film is lifted.
5. Do not use any type of abrasive substance on the Quartz Sleeve as it may be scratched.

Changing the Quartz Sleeve

1. Install Quartz Sleeve with Purple Seal (C) into the larger end of the Black Threaded Connector(A) so that half of the Purple Seal is still visible below the connection (about $\frac{1}{4}$ "). It should be a tight fit to create a good seal.
2. Take the White End Compression Nut (D) with threads facing up, slide it up the Quartz Sleeve from the bottom and screw on to the Black Threaded Connector(A).
3. Follow instructions for either the New Savio Skimmer Model or the Old Savio Skimmer Model.

AQUA ULTRAVIOLET PRODUCT LINE

For Easy Care Pond Maintenance Use Aqua Ultraviolet Sterilizers and Ultima II Filters

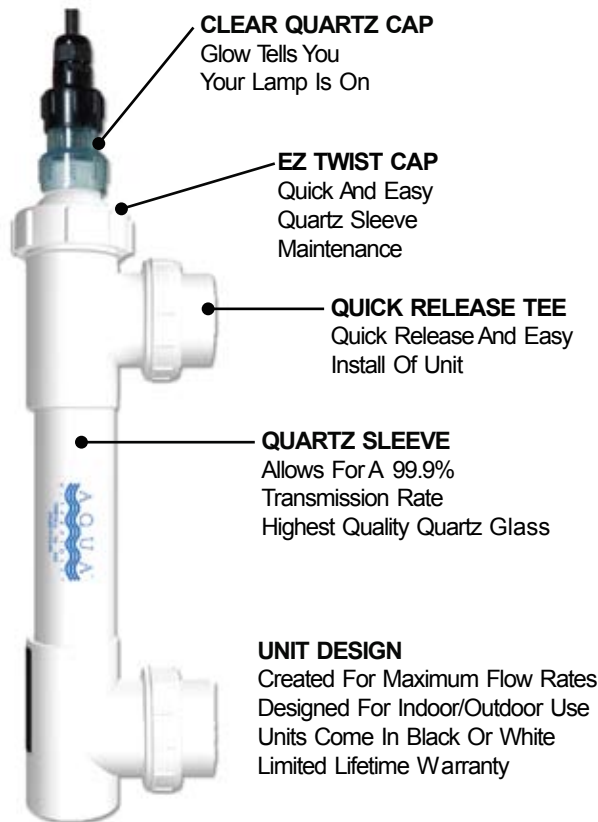

from **1,000** gallon size to **100,000** gallons

Aqua Ultraviolet media offers the highest surface area for growth of beneficial bacteria



Clear Water Guaranteed

- Destroys Harmful Bacteria
- Eliminates Algae (Green Water)
- Clears Your Water in 3-5 Days
- Industry's Longest Lamp Life ,14 Months
- Easy to Install and Maintain
- Optional Wiper keeps Quartz Sleeve Clean

If additional UV or Filtration is needed just plumb it in-line.

Bio-Mechanical Filtration

- Easy to Install and Maintain
- Just Minutes each Week for Backwash
- The Internal Jets do all the Work
- No Filter Pads to Scrub
- Your Hands Stay Clean

We recommend that a bottom drain is the optimum draw for Ultima II filter installation

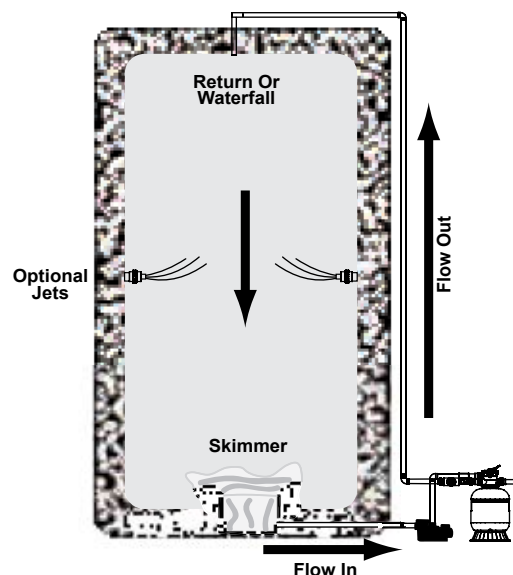
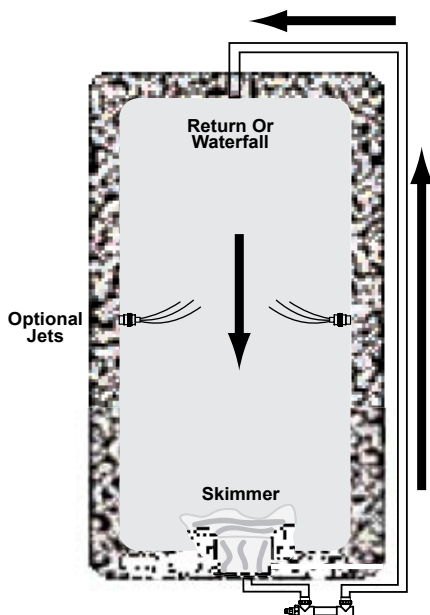

INCORRECT INSTALLATION

The following will damage the unit's electrical components and Quartz Sleeve.

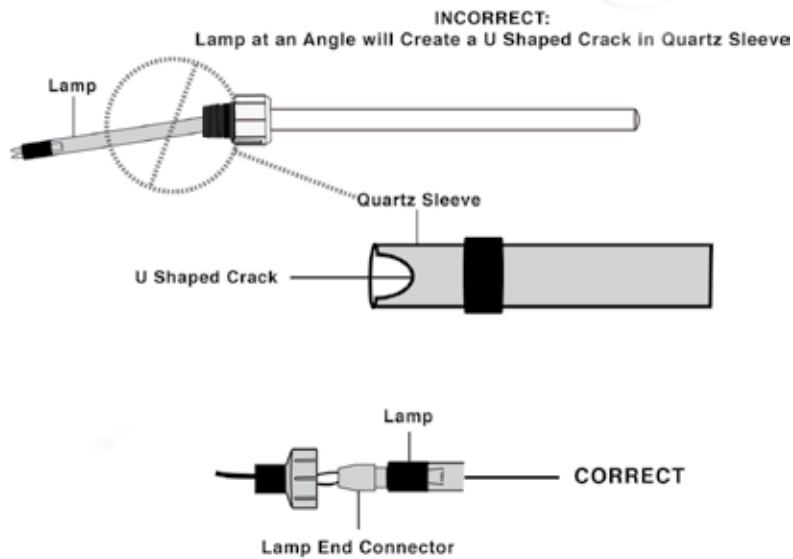

Lamp Dropped into the Quartz Sleeve can cause Breakage

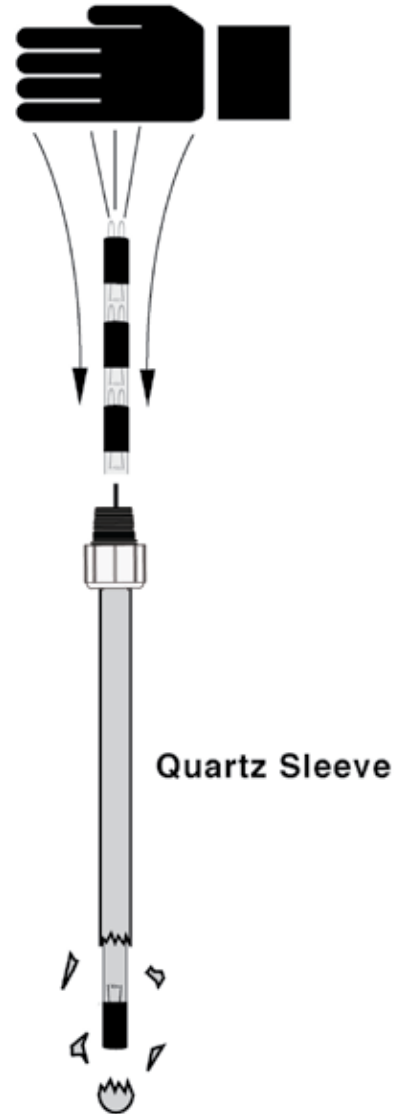

REPLACEMENT PARTS

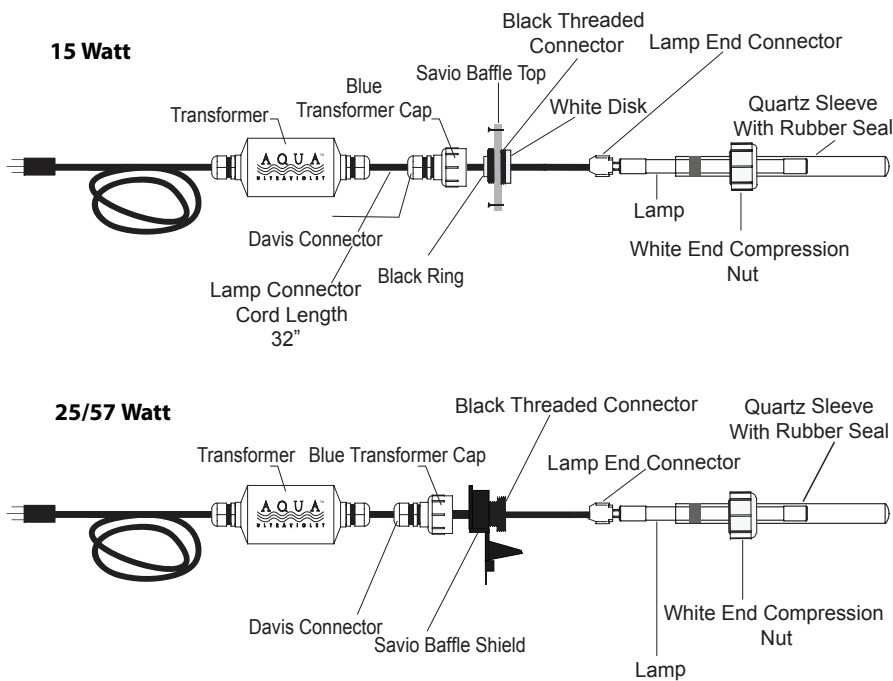

PART #	DESCRIPTION
A10015	15 Watt Quartz Sleeve w R/S
A10025	25 Watt Quartz Sleeve w R/S
A10057	57 Watt Quartz Sleeve w R/S
A20015	3/4" Black, Wiper
A20015	15 Watt Lamp
A20025	25 Watt Lamp
A20057	57 Watt Lamp
A30070	15 Watt Transformer
A30071	25 Watt Transformer
A30072	57 Watt Transformer
A40247	White End Compression Nut
A40004	Rubber Seal
A40108	Black Threaded Connector
A40248	15 Watt Savio Disk
A40249	Screw for Savio Disk
A40002	Lamp End Connector
A40109	Davis Connector
A40023	Transformer Blue Cap Clear

WARRANTY RETURNS OR REPAIRS

Please call Aqua Ultraviolet at (800) 454-2725 for a "Return Merchandise Authorization" (RMA) number. You must have a valid RMA from an Aqua Ultraviolet customer service representative before sending any product in for warranty or repair. Please have your serial number, date of purchase and product type available when calling for an RMA number.

All warranty returns or repair returns must come freight prepaid with an RMA number outside clearly marked on the box. All other returns will be refused. Aqua Ultraviolet will not be liable for any shipping cost to return warranty or repair items. Include a note in the box with your RMA number, name, address, daytime phone number and brief description of the reason for return or repair.

Be sure to return product in the same packing or similar packing and insure the package (we recommend sending it UPS). If you do not have or can't locate proper packaging, please call our customer service department and we will be more than happy to send you packaging for a minimal charge.

Aqua Ultraviolet shall not be responsible for damage or loss done by the shipper. Nor shall Aqua Ultraviolet be responsible for merchandise that arrives damaged due to improper packaging. All claims for loss and damage must be filed by the customer with the shipper.

If unit is found to be out of warranty we will contact you with the cost of repair. Your authorization is required prior to making any repairs.



42371 Avenida Alvarado
Temecula, CA 92590
TOLL FREE: (800) 454-2725
TEL: (951) 296-3480
FAX: (951) 296-3490
www.aquauv.com